

# F1PNR-HC

Type N Male Right Angle for 1/4 in FSJ1-50A cable



**OBSOLETE**

Replaced By:

F1TNR-HC

Type N Male Right Angle for 1/4 in FSJ1-50A cable

## Product Classification

<b>Product Type</b>	Wireless and radiating connector
<b>Product Brand</b>	HELIAX®

## General Specifications

<b>Body Style</b>	Right angle
<b>Cable Family</b>	FSJ1-50A
<b>Inner Contact Attachment Method</b>	Captivated
<b>Inner Contact Plating</b>	Gold
<b>Interface</b>	N Male
<b>Mounting Angle</b>	Right angle
<b>Outer Contact Attachment Method</b>	Self-clamping
<b>Outer Contact Plating</b>	Silver
<b>Pressurizable</b>	No

## Dimensions

<b>Height</b>	20.57 mm   0.81 in
<b>Width</b>	32.51 mm   1.28 in
<b>Length</b>	48.26 mm   1.9 in
<b>Right Angle Length</b>	48.26 mm   1.9 in
<b>Diameter</b>	23.88 mm   0.94 in

# F1P NR-HC

Nominal Size

1/4 in

## Outline Drawing

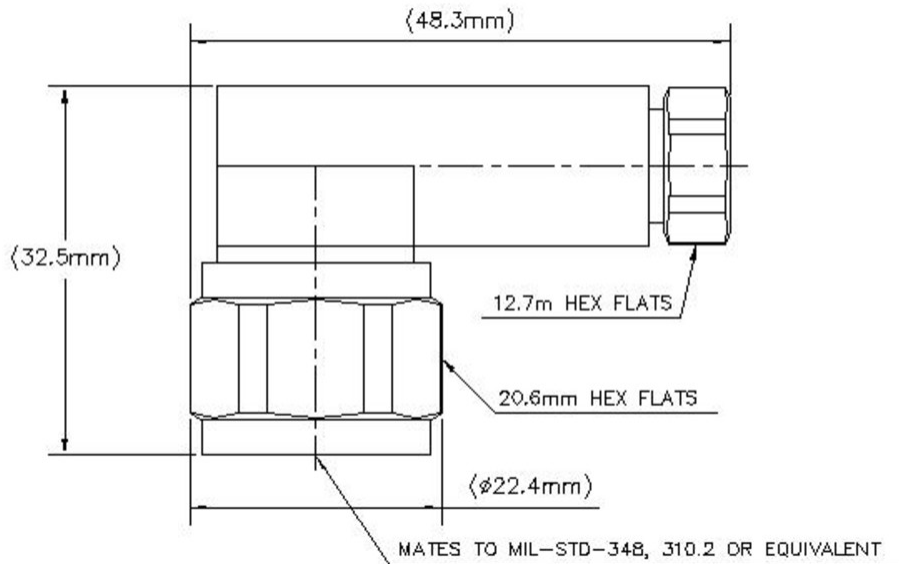

## Electrical Specifications

<b>3rd Order IMD at Frequency</b>	-112 dBm @ 910 MHz
<b>3rd Order IMD Test Method</b>	Two +43 dBm carriers
<b>Average Power at Frequency</b>	0.4 kW @ 900 MHz
<b>Cable Impedance</b>	50 ohm
<b>Connector Impedance</b>	50 ohm
<b>dc Test Voltage</b>	1600 V
<b>Inner Contact Resistance, maximum</b>	1 mOhm
<b>Insulation Resistance, minimum</b>	5000 MOhm
<b>Operating Frequency Band</b>	0 – 6000 MHz
<b>Outer Contact Resistance, maximum</b>	0.25 mOhm
<b>Peak Power, maximum</b>	6.4 kW
<b>RF Operating Voltage, maximum (vrms)</b>	565 V
<b>Shielding Effectiveness</b>	-110 dB

## Mechanical Specifications

# F1P NR-HC

---

<b>Connector Retention Tensile Force</b>	449.27 N   101 lbf
<b>Coupling Nut Proof Torque</b>	1.7 N-m   15.046 in lb
<b>Coupling Nut Proof Torque Method</b>	IEC 61169-16:9.3.11
<b>Coupling Nut Retention Force</b>	445 N   100.04 lbf
<b>Coupling Nut Retention Force Method</b>	IEC 61169-16:9.3.11
<b>Insertion Force</b>	124.55 N   28 lbf
<b>Insertion Force Method</b>	IEC 61169-16:9.3.5
<b>Interface Durability</b>	500 cycles
<b>Interface Durability Method</b>	IEC 61169-4:17
<b>Mechanical Shock Test Method</b>	IEC 60068-2-27

## Environmental Specifications

<b>Operating Temperature</b>	-55 °C to +85 °C (-67 °F to +185 °F)
<b>Storage Temperature</b>	-65 °C to +125 °C (-85 °F to +257 °F)
<b>Attenuation, Ambient Temperature</b>	20 °C   68 °F
<b>Average Power, Ambient Temperature</b>	40 °C   104 °F
<b>Average Power, Inner Conductor Temperature</b>	100 °C   212 °F
<b>Corrosion Test Method</b>	IEC 60068-2-11
<b>Moisture Resistance Test Method</b>	IEC 60068-2-3
<b>Thermal Shock Test Method</b>	IEC 60068-2-14
<b>Vibration Test Method</b>	IEC 60068-2-6

## Packaging and Weights

<b>Weight, net</b>	100 g   0.22 lb
--------------------	-----------------

## Regulatory Compliance/Certifications

<b>Agency</b>	<b>Classification</b>
ISO 9001:2015	Designed, manufactured and/or distributed under this quality management system

